

## AURALIZATION APPLYING THE PARAMETRIC ROOM ACOUSTIC MODELING TECHNIQUE - THE DIVA AURALIZATION SYSTEM

*Lauri Savioja and Tapio Lokki*

Telecommunications Software and  
Multimedia Laboratory  
Helsinki University of Technology  
P.O.Box 5400, FIN-02015 HUT, Finland  
Lauri.Savioja@hut.fi  
Tapio.Lokki@hut.fi

*Jyri Huopaniemi*

Nokia Research Center  
Speech and Audio Systems Lab.  
P.O.Box 407  
FIN-00045 Nokia Group  
Finland  
Jyri.Huopaniemi@nokia.com

### ABSTRACT

The primary goal of this paper is to give a general view on room acoustic modeling and auralization, and especially to describe the current status of the DIVA auralization system. We have been building the system for several years, and it has evolved a lot during that time. It is a room acoustic modeling and auralization system suitable for both real-time and non-realtime acoustic rendering, and it is designed for research purposes. It applies the parametric room impulse response rendering technique described in the article. In this paper we review the architecture and design principles of the system. A description of recent advances is given and results of perceptual evaluations are presented.

### 1. INTRODUCTION

The research problems related to the design of an auralization<sup>1</sup> system are illustrated in Fig. 1. The field is multidisciplinary and thus the implementation of the system requires understanding and knowledge of room acoustics, digital signal processing, and psychoacoustics. On a more general level the research problem in auralization is to model and simulate the sound propagation from sound sources to the ear drums of a listener through the modeled space. The research problems related to the design of an auralization system lie in the areas of room acoustic modeling, digital filter design, and 3D sound reproduction.

There are two main approaches in auralization. In the perceptual one the main emphasis is on the perceived sound whereas in the physics-based approach the physical behavior of sound is under simulation. The perceptual one is computationally less expensive, and therefore it is widely applied in the entertainment industry, for example, modern PC sound cards with 3-D sound capabilities utilize this approach. In physics-based modeling the goal is accurate simulation that can be utilized in applications with higher requirements such as in acoustical design of concert halls.

This paper is organized as follows. In Section 2 we make a brief review of the most important virtual acoustic systems available, and describe the background of the DIVA auralization system in more detail. In the next Section we discuss the basics of

<sup>1</sup>The term auralization has been defined by Kleiner et al. [1] as follows. *Auralization is the process of rendering audible, by physical or mathematical modeling, the sound field of a source in a space, in such a way as to simulate the binaural listening experience at a given position in the modeled space.*

parametric auralization. Section 4 is a description of perceptual evaluation of the DIVA auralization system. Guidelines for further development of the system are presented next. Finally, Section 6 concludes the paper.

### 2. BACKGROUND

In this Section, we present some currently available auralization systems and research institutes working in this field, and after that we concentrate on the DIVA auralization system and its history and applications.

#### 2.1. Auralization systems

Auralization and room acoustics have been researched in several places during the past decade. Each research institute has had its own specific area, and in the following we have made a rough division into three categories applying the same division as in Fig. 1. Please, note that only a couple of early references for each institute are presented. The list is not exhaustive, but only gives the most important ones from our viewpoint.

The idea of auralization and digital simulation and reproduction of room acoustics is quite old. The predecessors of auralization systems have been artificial reverberation algorithms. Since the pioneering work of Schroeder [2, 3] digital reverberators have been developed for professional audio and music industry. The

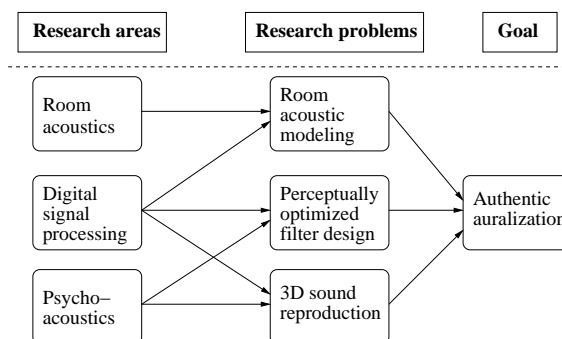

Figure 1: The research areas and problems involved in the design of an auralization system.

design goal in reverberators is similar to the one in auralization systems; to model a decaying sound field by producing a dense pattern of reflections.

Nowadays computers are widely applied to help in room acoustic design. Most of the available applications for this purpose also have their own module for auralization. Computational modeling of room acoustics and auralization has been the main area of research for the following organizations:

- One of the first attempts to model room acoustics and realize binaural auralizations of concert halls was realized in the Centre Scientifique et Technique du Batiment, France, [4, 5]. In addition, they were one of the firsts who proposed separate modeling of early reflections and statistical late reverberation.
- In the Technical University of Denmark, research on modeling of concert hall acoustics and auralization [6] has led to the room acoustic modeling program called Odeon<sup>2</sup>.
- A lot of research on modeling of reflections as well as basic research on auralization methods has been conducted in the Chalmers University of Technology, Sweden, [1, 7]. As a product of these studies the room acoustic modeling program, CATT Acoustic<sup>3</sup>, including auralization, has been developed. Recently, they have studied edge diffraction modeling successfully [8].
- The room acoustic simulation program EASE/EARS including auralization has been developed by the Acoustic Design Ahnert<sup>4</sup>, Germany, [9].
- In the University of Parma, Italy, a lot of research on concert hall and automotive acoustics, and sound systems inside cars [10] has been executed. In addition, they have produced the room acoustic modeling software Ramsete<sup>5</sup>.

The following research units have had a significant impact on the field of 3-D sound reproduction:

- In the Ruhr-Universität Bochum, Germany, a lot of basic research in room acoustic modeling and especially in human spatial hearing has been done [11, 12]. In addition, they have their own auralization system [13, 14].
- In the NASA-Ames Research Center, USA, the research has been driven by the interest to directional hearing and real-time systems [15, 16]. Recently, they have been building a real-time auralization tool, SLAB [17], for interactive spatial sound research.
- Binaural technology and HRTF measurement methods have been developed extensively in the Aalborg University, Denmark [18].
- Research on artificial reverberators and auralization have been carried out since 1992 in the Massachusetts Institute of Technology, USA, [19]. Further development of this work has led to pro audio softwares by *Wave Arts*<sup>6</sup>.

The leading research institute concerning perception-based real-time auralization has been the IRCAM (Institut de Recherche et

<sup>2</sup><http://www.dat.dtu.dk/~odeon/>

<sup>3</sup><http://www.catt.se/>

<sup>4</sup><http://www.ada-acousticdesign.de/>

<sup>5</sup><http://www.ramsete.com/>

<sup>6</sup><http://www.wavearts.com/>

Coordination Acoustique/Musique) in France. For example, they have created a spatializer tool, Spatialisateur, for musicians with perceptual modeling approach [20, 21, 22]. Especially, they have developed signal processing algorithms for efficient rendering and for real-time systems.

## 2.2. History and design goals of the DIVA auralization system

At the Helsinki University of Technology (HUT) research on room acoustic modeling and 3-D sound reproduction has been conducted since early 1990's. In 1994 first attempts to combine these efforts were made. Since then we have developed the Digital Interactive Virtual Acoustics (DIVA) auralization system for room acoustic modeling aiming at both real-time and non-realtime auralization.

In the first DIVA auralization system we applied a dedicated DSP-processor for auralization, but already in 1994 we also had an implementation running on a UNIX-workstation, and after that we have been working entirely without any special hardware. In the original version, headphone reproduction was applied, but currently both multichannel reproduction with loudspeakers and binaural reproduction with headphones are supported.

The DIVA auralization system has been a part of a more complex system aiming at virtual concert performance. As a result we had our own virtual orchestra. The first public performance of the DIVA virtual orchestra was in 1997 in SIGGRAPH'97 conference in Los Angeles. Another demonstration of the DIVA auralization system was the Marienkirche video presenting the acoustic design of a concert hall. The video was presented in the Electronic Theater of SIGGRAPH'98 conference [23], and after that it has been shown on several TV-channels worldwide.

## 3. ROOM ACOUSTIC MODELING AND AURALIZATION

In room acoustic modeling the propagation of sound waves in a space is under study. This can be divided into two subparts: modeling of the actual propagation and modeling of reflections from boundaries of a space. The modeling of wave propagation is quite straightforward. In a free space each sound source emits a spherical wavefront, i.e., an elementary wave, that propagates homogeneously in all directions. The amplitude of sound is inversely proportional to the distance from the sound source. Modeling of reflections is a bit more challenging. In each reflection a new wavefront is created, and the reflections can be modeled as new sound sources. Therefore it is possible to reduce the model such that recursively in each reflection a new sound source is created. Finally we have only sound sources, but no reflections. In actual modeling the effect of each source is composed to produce the final sound field in the listening positions. However, some of these secondary sources are not visible to a listening point due to occlusion by surfaces. For this reason validity of all sources is verified with a visibility check. One of the most commonly applied room acoustic modeling techniques is called the image source method [24], and it is based on this approach.

Figure 2 illustrates this concept of sound field decomposition [25]. Each reflection from a wall is replaced with an image source and each corner (except convex rectangular corners) is replaced with an edge source. All of these secondary sources emit a wavefront that are shown inside the geometry. With the concept of image sources each elementary wave can be easily filtered with frequency dependent acoustic phenomena such as sound source directivity, distance delay and attenuation, air, material, and wall ab-

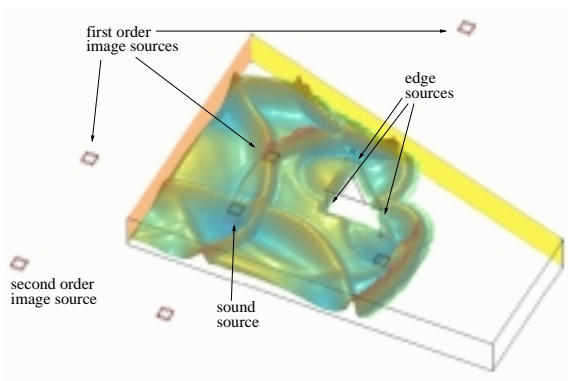

Figure 2: An example of the sound field decomposition into the elementary waves with the image-source method. The illustration is done by computing an impulse response in each pixel and by plotting the time moment of 680<sup>th</sup> sample which corresponds to 14.2 ms in time.

sorption which are all included to the simulation shown in Fig. 2. When auralizing the elementary waves for headphone reproduction the binaural features of human hearing can be considered as well, as proposed by Borish almost twenty years ago [26].

The most straightforward method to realize auralization is to measure or model binaural room impulse responses (BRIR) and convolve them with anechoic signals. This method is called the *direct room impulse response rendering method*. The technique is computationally heavy, and implementation of dynamic systems is difficult. This is caused by the fact that in dynamic rendering the BRIRs have to be measured from all the possible locations of a listener. In practice this can be implemented by making the measurements with a certain grid, and during auralization the exact response is obtained with interpolation.

### 3.1. Parametric room impulse response rendering

The DIVA auralization system applies the *parametric room impulse response rendering method* in which the BRIRs are not calculated before the actual auralization process. Instead, a set of either perception- or physics-based parameters for the auralization process is defined. Such parameterization enables a more robust way for dynamic and real-time rendering than the direct room impulse response rendering [27].

The DIVA auralization system is based on room acoustic modeling and aims at perceptually authentic rendering of the modeled space. In our system the modeling is divided into two parts. The first part is time and place variant containing modeling of the direct sound and early reflections. The image source method is applied for this purpose. The second part is for rendering the late reverberation that is assumed to be diffuse such that its parameters do not change as a function of time or place.

The image source method implemented in the DIVA auralization system gives the following parameters for each image source:

- order of reflection,
- orientation (azimuth and elevation angles) of sound source,
- distance from the listener,
- incoming direction of sound (azimuth and elevation angle in relation to the listener),

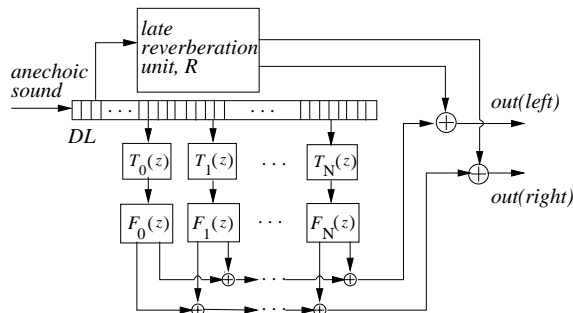

Figure 3: The signal processing structure of the DIVA auralization system [28, 27]. In this example the output is binaural.

- set of filter coefficients describing the material properties in reflections,
- required parameters for calculation of response from a diffracting edge in the case of an edge source.

The parameters of late reverberation are pre-calculated based either on measurements or results of room acoustic modeling. By this technique we can tune the reverberation time and some other essential features of reverberance according to the properties of the space.

### 3.2. Audio signal processing

In the DIVA auralization system the image-source calculation provides the auralization parameters which are finally converted to signal processing parameters. The reason for this two level process is the fact, that in dynamic rendering the auralization parameters do not need to be updated for every audio sample. However, the signal processing parameters have to be defined on a sample by sample basis. In the DIVA auralization system this is achieved by interpolating the signal processing parameters between the updates of auralization parameters.

The signal processing structure utilized in the DIVA auralization system is depicted in Fig. 3. It contains a long delay line  $DL$  which is fed with anechoic sound to be processed. The distance of the image source from the listener defines the pick-up point to the filter block  $T_k(z)$ , where  $k = 0, 1, 2, \dots, N$  is the identifier of the image source ( $k = 0$  corresponds to the direct sound). Blocks  $T_{0\dots N}(z)$  modify sound signal with the sound source directivity filters, distance dependent gains, air absorption filters and material filters (not for the direct sound). The incoming direction of the sound is defined with blocks  $F_{0\dots N}(z)$  containing directional filtering or panning depending on the reproduction method. The superimposed outputs of the filters  $F_{0\dots N}(z)$  are finally summed with the outputs of the late reverberation unit  $R$  which is a complex recursive algorithm.

### 3.3. Modeling of diffraction

The most recent advancement in the DIVA auralization system is the diffraction modeling, and it is described in more detail in this section. Svensson et al. [8] have derived a mathematical solution for calculating the impulse response for an edge of a finite length. The impulse response is calculated from the source to the listening position through the edge. With this analytical solution the

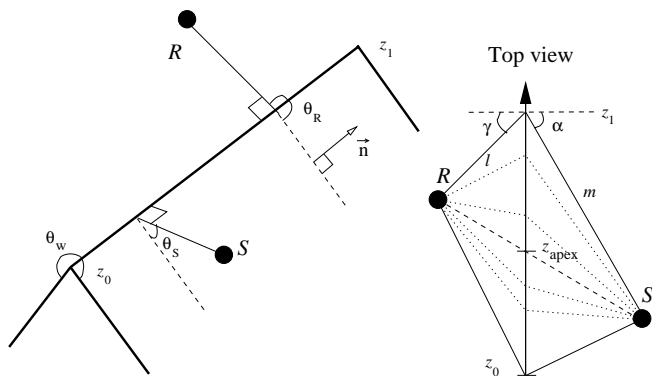

Figure 4: Geometry of a finite wedge. The positions of source  $S$  and receiver  $R$  are indicated in cylindrical coordinates. On the right, sound paths via edge points  $z_0$  and  $z_1$  are indicated by the solid lines, the least-time sound path via the apex point  $z_{apex}$  is depicted with dashed line and some other sound paths are illustrated with dotted lines.

edge diffraction is modeled to the DIVA auralization system. The auralization parameters for an edge source are:

- wedge angle  $\theta_w$ ,
- position of source  $S(x, y, z)$ ,
- position of receiver  $R(x, y, z)$ ,
- start and end point of the edge  $Z_0(x, y, z); Z_1(x, y, z)$ ,
- normal vector  $\vec{n}$  of a surface.

With this data for each edge, the impulse response is calculated with the following equations [8, 29]:

$$h(t) = -\frac{\nu}{4\pi} \int_{z_0}^{z_1} \delta\left(t - \frac{m+l}{c}\right) \frac{\beta_{+++} + \beta_{+-} + \beta_{-+} + \beta_{--}}{ml} dz, \quad (1)$$

$$\beta_{\pm\pm\pm} = \frac{\sin[\nu(\pi \pm \theta_S \pm \theta_R)]}{\cosh\left(\nu \cosh^{-1} \frac{1 + \sin \alpha \sin \gamma}{\cos \alpha \cos \gamma}\right) - \cos[\nu(\pi \pm \theta_S \pm \theta_R)]}. \quad (2)$$

An example of a finite wedge is depicted in Fig. 4 to illustrate the variables. In addition,  $c$  is speed of sound,  $\nu = \pi/\theta_w$  is the wedge index,  $m$  is the source-to-edge point distance, and  $l$  is the edge point-to-receiver distance. The integration range is between the two end points of a finite edge.

Based on the impulse responses we have designed diffraction filters that implement the diffraction phenomenon as an impulse response in one point [29], but in real life diffraction sources are not point-like. Sound passes the edge through all points along the edge, however, most of the energy is concentrated on the least-time point of the edge. Based on this, the simplification to a point-like secondary source is not too severe. In addition, the diffraction image source, being a point source, can be panned to the direction the least-time point indicates as proposed by Torres et al. [30]. The same principle holds for the sound source directivity, since from the viewpoint of the edge most of the sound energy from the actual source radiates towards the least-time point of the edge. The

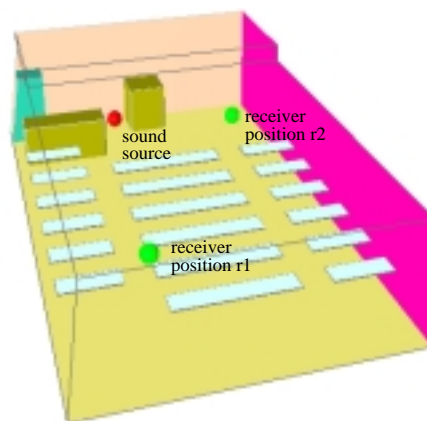

Figure 5: The geometry of the studied lecture room and the positions of the sound source and two receiver positions, utilized in the evaluation. In both receiver positions the listener was looking straightly forward.

situations where this simplification could be most audible would be long edges that are close to the listener.

In the current implementation the edge diffraction filters are designed between image source calculation and auralization processes. As such, our implementation is not practical for real-time use, but dynamic off-line rendering is straightforward.

#### 4. PERCEPTUAL EVALUATION

In the design and implementation of the DIVA auralization system we have pursued towards an ultimate goal of an authentic auralization in which a listener is unable to distinguish a simulated sound from a recorded sound. For this reason our system has been evaluated by both objective and subjective means. The main emphasis on this Section is on the subjective case, but first the objective approach is briefly reviewed. In both cases the careful analysis is performed with a model of one lecture hall at the HUT as illustrated in Fig. 5.

The objective evaluation has been based on calculation of room acoustic attributes such as reverberation time (T20), early decay time (EDT) and clarity (C50). These attributes have been obtained both from the simulation results and from the corresponding measured impulse responses. In general, the results show that above 400Hz the attributes coincide quite well. However, below that there are some minor defects in modeling, for example, the auralizations are less reverberant than the recordings on that frequency range.

##### 4.1. Evaluation framework

The perceptual evaluation of auralization quality was based on the framework illustrated in Fig. 6 [31]. The evaluation was performed by comparing recorded and auralized sound-tracks. The recordings made in the studied lecture room were considered as reference signals.

To find out subjective perceptual differences between the recorded and the auralized sound-tracks several listening tests have been carried out.

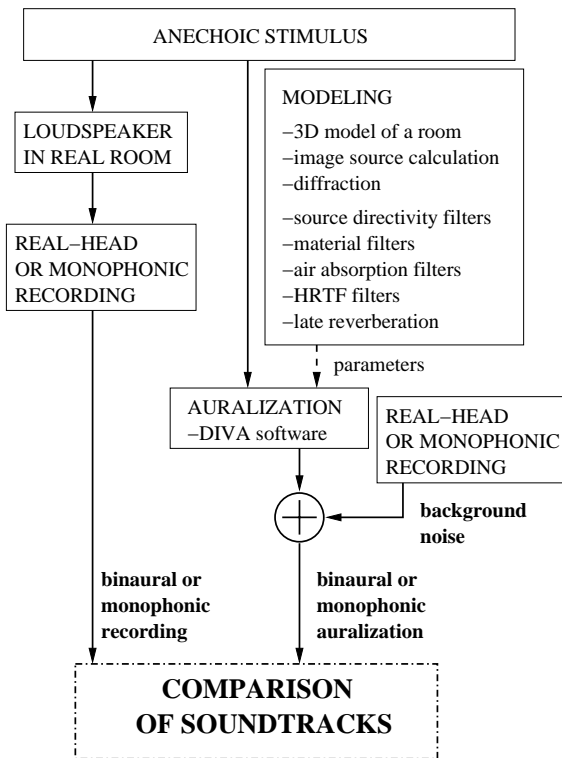

Figure 6: A framework for evaluation of virtual acoustic system.

Different listening test methods have been tried out due to the reason that no recommended listening test methodology for testing the auralization quality exists. Finally, we chose to apply the ABX paradigm. The method utilizes double-blind triple stimulus with hidden reference, including interval scales [32].

The quality of auralization has many different aspects and it is multidimensional by nature. Of course, subjects could only judge whether the sound-tracks differ or not, but then no information about the nature of differences is achieved. To obtain more information about possible differences, two attributes, namely spatial and timbral differences, have been studied.

The assessment has been an iterative process containing several evaluation rounds. Totally 20 subjects (three females and 17 males) participated in the final listening test. All of them reported normal hearing although this was not verified with audiometric tests. The test was done in a standard listening room and the headphone reproduction method was applied with Sennheiser HD-580 headphones.

The listening task was to compare spatial and timbral differences between the recorded and the auralized sound-tracks. Subjects were told to quantify sound source location, size of space, and reverberation when considering spatial differences. Similarly, such attributes as color of sound and frequency content was advised to be listened for judging timbral differences.

#### 4.2. Evaluation Results

The results of the listening tests show that for certain types of signals we have achieved auralizations that are nearly imperceptible from the corresponding recordings. In general, there were no sig-

nificant differences between the grades given to spatial and timbral properties. Signals having sustained tonal characteristics such as sound of a clarinet were judged with the best grades. With signals having transients such as a hit of a snare drum the differences were clearly audible but on the average they were evaluated to be plausible and natural sounding.

#### 5. FUTURE GUIDELINES

The current modeling techniques applied typically in room acoustic design are based on the geometrical acoustics. In the future, the phenomena caused by the wave-nature of sound should be modeled more carefully. This can be done either by employing some wave-based model such as the digital waveguide mesh [33], or by adding their modeling into existing ray-based systems.

The next major improvement to the DIVA auralization system will be modeling of diffusion. In general, diffusion plays an important role in room acoustics. For example, in concert halls the sidewalls are typically made to be diffusive rather than specularly reflecting. Our approach to this problem will be to incorporate diffusion into the image-source method by using surface sources based on the ideas suggested by Dalenbäck [34]. In addition, we are going to further enhance the auralization quality by continuing both subjective and objective evaluations.

#### 6. CONCLUSIONS

The research on auralization has gained significant progress during the past decade. Current computers are computationally efficient and thus enable elaborate audio signal processing required in high-quality auralization. In the DIVA auralization system developed at the HUT the latest improvements have incorporated modeling of diffraction into the system. The quality of the DIVA auralization system has been assessed with several listening tests. At the best the quality has been shown to be so good that the listeners have been unable to distinguish between recorded and simulated sound tracks. In the future the quality of auralization systems will still improve due to more efficient computers and advances in the modeling techniques.

#### 7. ACKNOWLEDGMENTS

This work has been supported by the Academy of Finland through the Helsinki Graduate School in Computer Science.

#### 8. REFERENCES

- [1] M. Kleiner, B.-I. Dalenbäck, and P. Svensson, "Auralization – an overview," *J. Audio Eng. Soc.*, vol. 41, no. 11, pp. 861–875, 1993 Nov.
- [2] M. R. Schroeder, "Natural-sounding artificial reverberation," *J. Audio Eng. Soc.*, vol. 10, no. 3, pp. 219–223, 1962.
- [3] M. Schroeder and B. Atal, "Computer simulation of sound transmission in rooms," *IEEE Conv. Record*, vol. 11, no. 7, pp. 150–155, 1963.
- [4] J.P. Vian, "Different computer modelling methods – their merits and their applications," in *Proc. 12th Int. Congr. Acoust. (ICA'86)*, Toronto, Ont., Canada, July 1986, vol. paper E4-10.

- [5] D. van Maercke, "Simulation of sound fields in time and frequency domain using a geometrical model," in *Proc. 12th Int. Congr. Acoust. (ICA'86)*, Toronto, Ont., Canada, July 1986, vol. 2, paper E11-7.
- [6] G. M. Naylor, "ODEON – another hybrid room acoustical model," *Applied Acoustics*, vol. 38, no. 2-4, Special Issue on Computer Modelling and Auralisation of Sound Fields in Rooms, pp. 131–143, 1993.
- [7] B.-I. Dalenbäck, *A New Model for Room Acoustic Prediction and Auralization*, Ph.D. thesis, Chalmers Univ. of Tech., Gothenburg, Sweden, 1995.
- [8] U.P. Svensson, R.I. Fred, and J. Vanderkooy, "Analytic secondary source model of edge diffraction impulse responses," *J. Acoust. Soc. Am.*, vol. 106, no. 5, pp. 2331–2344, 1999.
- [9] W. Ahnert and R. Feistel, "EARS auralization software," *J. Audio Eng. Soc.*, vol. 41, no. 11, pp. 894–904, Nov. 1993.
- [10] A. Farina, "Verification of the accuracy of the pyramid tracing algorithm by comparison with experimental measurements of objective acoustic parameters," in *Proc. 15th Int. Congr. Acoust. (ICA'95)*, Trondheim, Norway, June 1995, pp. 445–448.
- [11] H. Lehnert and J. Blauert, "Principles of binaural room simulation," *Applied Acoustics*, vol. 36, no. 3-4, pp. 259–291, 1992.
- [12] J. Blauert, *Spatial Hearing. The Psychophysics of Human Sound Localization*, MIT Press, Cambridge, MA, 2nd edition, 1997.
- [13] J. Blauert, H. Lehnert, J. Sahrhage, and H. Strauss, "An interactive virtual-environment generator for psychoacoustic research. I: Architecture and implementation," *Acustica united with Acta Acustica*, vol. 86, no. 1, pp. 94–102, 2000.
- [14] T. Djelani, C. Prschmann, J. Sahrhage, and J. Blauert, "An interactive virtual-environment generator for psychoacoustic research. II: Collection of head-related impulse responses and evaluation of auditory localization," vol. 86, no. 6, pp. 1046–1053, 2000.
- [15] S. Foster, E. Wenzel, and R. Taylor, "Real-time synthesis of complex acoustic environments," in *Proc. IEEE Workshop on Applications of Signal Processing to Audio and Acoustics*, Mohonk, New Paltz, NY, 1991.
- [16] D. Begault, *3-D Sound for Virtual Reality and Multimedia*, Academic Press, Cambridge, MA, 1994.
- [17] E. M. Wenzel, J. D. Miller, and J. S. Abel, "Sound lab: A real-time, software-based system for the study of spatial hearing," in *the 108th Audio Engineering Society (AES) Convention, preprint no. 5140*, Paris, Feb. 2000.
- [18] H. Møller, "Fundamentals of binaural technology," *Applied Acoustics*, vol. 36, no. 3-4, pp. 171–218, 1992.
- [19] W. Gardner, "Virtual acoustic room," M.S. thesis, MIT, 1992.
- [20] J.-M. Jot and A. Chaigne, "Digital delay networks for designing artificial reverberators," in *The 90th Convention of the Audio Engineering Society*, Paris, France, 1991, preprint 3030.
- [21] J.-M. Jot, "An analysis/synthesis approach to real-time artificial reverberation," in *Proc. 1992 IEEE Int. Conf. Acoust., Speech, and Signal Processing*, San Francisco, CA, March 1992, vol. 2, pp. 221–224.
- [22] J.-M. Jot, *Etude et réalisation d'un spatialisateur de sons par modèles physique et perceptifs*, Ph.D. thesis, l'Ecole Nationale Supérieure des Télécommunications, Télécom Paris, Sept. 1992.
- [23] T. Takala, E. Rousku, T. Lokki, L. Savioja, J. Huopaniemi, R. Väänänen, V. Pulkki, and P. Salminen, "Marienkirche - a visual and aural demonstration film," in *Electronic Art and Animation Catalogue (SIGGRAPH'98)*, Orlando, FL, July 1998, p. 149, Presented in SIGGRAPH'98 Computer Animation Festival (Electronic Theater).
- [24] J. B. Allen and D. A. Berkley, "Image method for efficiently simulating small-room acoustics," *J. Acoust. Soc. Am.*, vol. 65, no. 4, pp. 943–950, 1979.
- [25] U.P. Svensson and U.R. Kristiansen, "Computational modeling and simulation of acoustic spaces," in *Proc. AES 22nd Int. Conf. on Virtual, Synthetic and Entertainment Audio*, Espoo, Finland, June 15-17 2002.
- [26] J. Borish, "Extension of the image model to arbitrary polyhedra," *J. Acoust. Soc. Am.*, vol. 75, no. 6, pp. 1827–1836, 1984.
- [27] L. Savioja, J. Huopaniemi, T. Lokki, and R. Väänänen, "Creating interactive virtual acoustic environments," *J. Audio Eng. Soc.*, vol. 47, no. 9, pp. 675–705, Sept. 1999.
- [28] L. Savioja, J. Huopaniemi, T. Lokki, and R. Väänänen, "Virtual environment simulation - advances in the DIVA project," in *Proc. Int. Conf. Auditory Display (ICAD'97)*, Palo Alto, CA, Nov. 1997, pp. 43–46.
- [29] T. Lokki, P. Svensson, and L. Savioja, "An efficient auralization of edge diffraction," in *Proc. AES 21st Conference on Architectural Acoustics and Sound Reinforcement*, St. Petersburg, Russia, June 2002.
- [30] R.R. Torres, U.P. Svensson, and M. Kleiner, "Computation of edge diffraction for more accurate room acoustics auralization," *J. Acoust. Soc. Am.*, vol. 109, no. 2, pp. 600–610, 2001.
- [31] T. Lokki, J. Hiipakka, and L. Savioja, "A framework for evaluating virtual acoustic environments," in *the 110th Audio Engineering Society (AES) Convention*, Amsterdam, the Netherlands, May 2001, preprint no. 5317.
- [32] ITU-R, "Recommendation BS.1116-1, Methods for the subjective assessment of small impairments in audio systems including multichannel sound systems," International Telecommunication Union Radiocommunication Assembly, 1997.
- [33] L. Savioja and V. Välimäki, "Interpolated 3-D digital waveguide mesh with frequency warping," in *Proc. Int. Conf. Acoust., Speech, Signal Processing*, Salt Lake City, UT, May 2001.
- [34] B.-I. Dalenbäck, "Room acoustic prediction based on a unified treatment of diffuse and specular reflection," *J. Acoust. Soc. Am.*, vol. 100, no. 2, pp. 899–909, Aug. 1996.